



planers

surface planers, thickening planers, combined surface planer-thicknessers.

scmplaners

The widest range of planers available on the market.

L'invincibile

L'invincibile

the exclusive choice for your success.

surface planer

f 5200

thicknessing planers

s 6300

s 5200

class

class

the best solution
for every application.

surface planers

f 520

f 410

thicknessing planers

s 630

s 520

combined surface planer-thicknesser

fs 520

nova

nova

guaranteed quality
at your fingertips.

surface planers

f 520

f 410

thicknessing planers

s 630

s 520

combined surface planer-thicknesser

fs 410

F 5200 L'INVINCIBILE
page 05



F 520 CLASS
page 05



F 410 CLASS
page 05



F 520 NOVA
page 05



F 410 NOVA
page 05





| S 6300 L'INVINCIBILE
page 10



| S 5200 L'INVINCIBILE
page 10



| S 630 CLASS
page 10



| S 520 CLASS
page 10



| S 630 NOVA
page 10



| S 520 NOVA
page 10



| FS 520 CLASS
page 16



| FS 410 NOVA
page 16



surface **planers**

Perfect surfaces, practical and safe, ergonomic.





SURFACE PLANERS		L'INVINCIBILE	CLASS		NOVA	
		F 5200	F 520	F 410	F 520	F 410
Working width	mm	520	520	410	520	410
Total worktable length	mm	3.008	2.750	2.610	2.750	2.610
Infeed worktable length	mm	1.775	1.550	1.450	1.550	1.450
Cutterblock diameter (no. of knives)	mm	120 (4)	120 (4)	120 (4)	120 (4)	120 (4)
Cutterblock speed	rpm	5.000	5.000	5.000	5.000	5.000
Surface fence dimensions	mm	1.500 x 175	1.200 x 190	1.200 x 190	1.200 x 190	1.200 x 190
Surface fence tilting		from 90° to -45°	from 90° to -45°	from 90° to -45°	from 90° to -45°	from 90° to -45°
Main motor power	kW	7	5	5	5	5
Exhaust outlet diameter	mm	120	120	120	120	120
Extraction flow rate to 25 m/sec	m ³ /h	1.050	1.050	1.050	1.000	1.000
Basic machine weight	kg	855	752	665	720	560

surface planers

Devices and options.

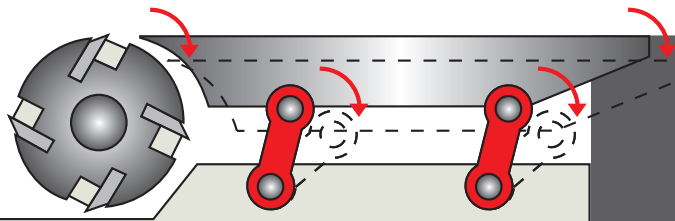

A

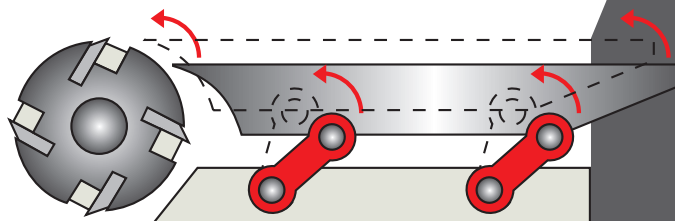

B

toptech

FEEDING ON CONNECTING RODS: CONSTANT PRECISION OVER TIME.

All machining with maximum safety with the movement of the infeed table by means of a parallelogram kinetic mechanism which always gives the same distance between the cutterblock and the table. The system operating directly on the connecting rods avoids any exertion to the table assuring constant planarity over time.

INTEGRATED GUARD: ERGONOMIC AND SAFE.

The cutterblock guard with integrated support in the machine base (SCM patented solution) represents the constant commitment to providing the woodworker with the very best and safest working conditions.

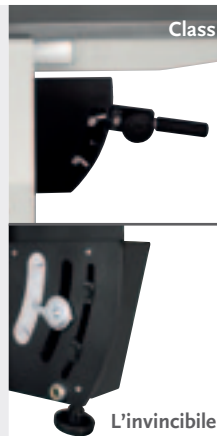
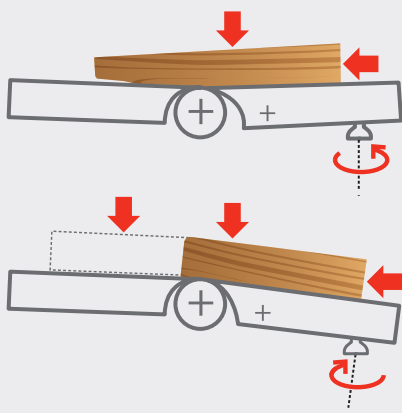

CONCAVE / CONVEX FUNCTION: PERFECT JOINTS EVERY TIME.

The available settings allow perfect bonding of the components giving excellent coupling and eliminating any joint line. The device on the L'invincibile planer allows the setting of previous positions by the use of mechanical stops.



**CAST IRON WORK TABLES:
HIGH QUALITY FINISH.**

Vibration free movement due to the large worktables made from ribbed cast-iron with feeding on connecting rods ensuring perfect surfaces. The exhaust hood on the cutterblock allows improved efficiency and provides high quality machining.



toptech
**“SMART LIFTER” INTEGRATED PROTECTION:
ERGONOMICS AND SAFETY.**

The SCM patented protection system is perfectly integrated into the machine base for **maximum protection** while excluding any hindrance or obstruction in the work. The protection with automatic vertical, horizontal and tilted movements provides **complete coverage of the tool** before, during and after machining.



<http://goo.gl/rBool>

surface planers

Devices and options.

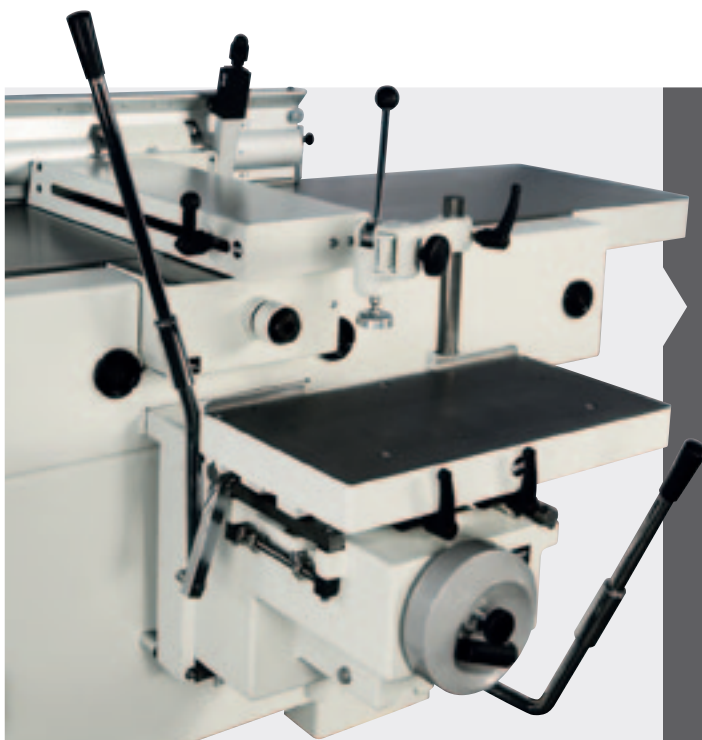

MORTISER: SOLUTIONS DESIGNED FOR THE "PROFESSIONAL WOODWORKER".

The large dimensioned cast-iron work table (530x330mm) guarantees the very best support of the work piece during machining and it can be easily handled in all movements with wide strokes (120mm longitudinal, 200mm cross, 165mm vertical).

ADDITIONAL OVERTURNING FENCE: USER-FRIENDLY AND SAFE.

The additional overturning fence, integrated in the surface fence, ensures perfect operator safety when machining small dimensioned workpieces.



SCM MONOBLOCK CUTTERBLOCK: EASY AND RAPID IN USE.

Ease of use and rapid changeover of the throwaway knives due to the automatic locking/unlocking system and with self-adjustment. The cutter block is made from a single block of steel ensuring complete stability even under heavy dynamic loads.





SURFACE PLANERS	L'INVINCIBILE	CLASS		NOVA	
	F 5200	F 520	F 410	F 520	F 410
Mobile control panel	S	S	S	-	-
Electrical movement of infeed table	S	S	-	-	-
Manual movement of infeed table	-	-	S	S	S
Electronic digital readout of thickening cutting depth	S	S	-	-	-
Analogue readout of cutting depth	-	-	S	S	S
Concave/convex function	S	S	-	-	-
Planer protection integrated in the machine base	S	S	S	-	-
"Smart Lifter" for planer protection integrated in the machine base	O	O	O	-	-
Additional overturning fence	O	O	O	O	O
Mortiser	O	O	O	O	O
"Tersa" cutterblock with throwaway knives	O	O	O	O	O

S= standard O= option -= not available

thicknessing **planers**

Easy to use and precise, stylish with practical design,
a wider range of applications.



THICKENING PLANERS		L'INVINCIBILE		CLASS		NOVA	
		S 6300	S 5200	S 630	S 520	S 630	S 520
Working width	mm	630	520	630	520	630	520
Work table dimensions	mm	640 x 1.000	530 x 900	640 x 1.000	530 x 900	640 x 1.000	530 x 900
Maximum working height	mm	300	300	300	300	300	300
Minimum working height	mm	3,5	3,5	3,5	3,5	3,5	3,5
Minimum working length	mm	260	220	260	220	260	220
Maximum stock removal in a single passage	mm	8	8	8	8	8	8
Feeding rollers diameter	mm	85	67	85	67	85	67
Cutterblock diameter (no. of knives)	mm	120 (4)	120 (4)	120 (4)	120 (4)	120 (4)	120 (4)
Spindle speed	rpm	4.500	4.500	4.500	4.500	4.500	4.500
Feed speed	m/min	4÷20	4÷20	4÷20	4÷20	5-8-12-18	5-8-12-18
Main motor power	kW	9	7	7	7	7	7
Feed motor power	kW	1,3	1,3	1,3	1,3	-	-
Exhaust outlet diameter	mm	150	150	150	150	150	150
Extraction flow rate to 25 m/min	m ³ /h	1.600	1.600	1.600	1.600	1.600	1.600
Basic machine weight	kg	965	745	925	680	785	680



thickening planers

Devices and options.



toptech

FEEDING ROLLERS ON CONNECTING ROADS: PERFECT FINISH.

The **stopping** of the work piece and the **presence of notches** on its surface are **eliminated** due to the movement system on all three rollers that allows their vertical displacement by rotation and the best linear feeding.

RUBBER ROLLERS: MAXIMUM EFFICIENCY AVAILABLE AS STANDARD.

Perfect surfaces and high feeding performance with the standard rubber rollers.



<http://goo.gl/4Gquj>

toptech

INTERCHANGEABLE ROLLERS: ONE MACHINE FOR EVERY REQUIREMENT.

Perfect finish obtained by quick and easy changeover of the rollers that allows the operator to configure the machine drive function in case of special requirements such as a **minimum removal** of fine wood and/or batches where multiple pieces of different thicknesses are processed. The operator does this by simply replacing the first toothed steel roller with a rubber roller.

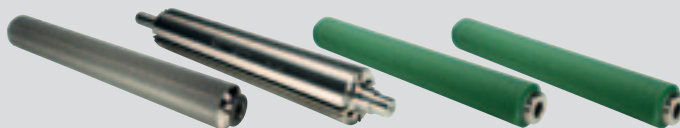
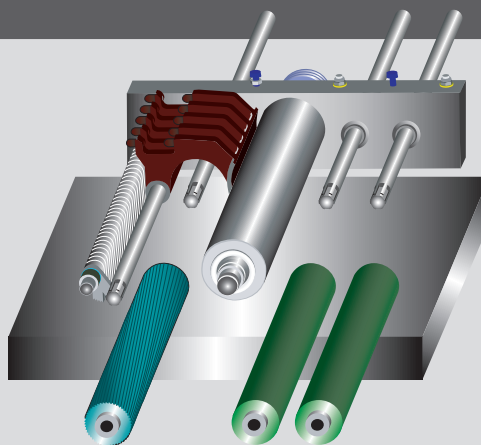

Basic configuration with grooved infeed roller in steel

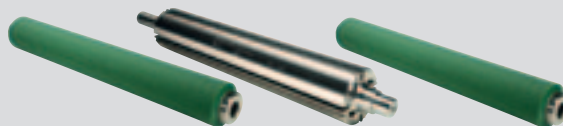

The grooved roller in steel is removed and has been substituted by the second outfeed rubber roller



<http://goo.gl/Ga8qL>



WORK TABLE MOVEMENT: STURDY STRUCTURE WITH PRECISION.

The 4 screws with a large diameter combined with the 2 side linear guides ensure **worktable stability** eliminating the necessity of locking in position.

The integrated protections guarantee **high precision and reliability over time**.

ELECTRONIC ADJUSTMENT OF THE FEED SPEED: BEST FINISH AT MAXIMUM SPEED.

The optimum feed speed is automatically adjusted by the SCM specific management system, which controls the power consumption of the main motor (planer group), ensuring the **best possible finishing quality and avoiding the overloading of the motor** (*L'invincibile range*).

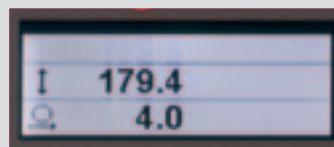

<http://goo.gl/2MEeQ>

FEED SPEED BY MEANS OF AN INVERTER HIGHER PRODUCTIVITY.

Control of the variable feed speed by means of a user-friendly adjusting device on the front control panel that guarantees the best quality finish. Dedicated warning light to indicate too higher speed (*class range*).

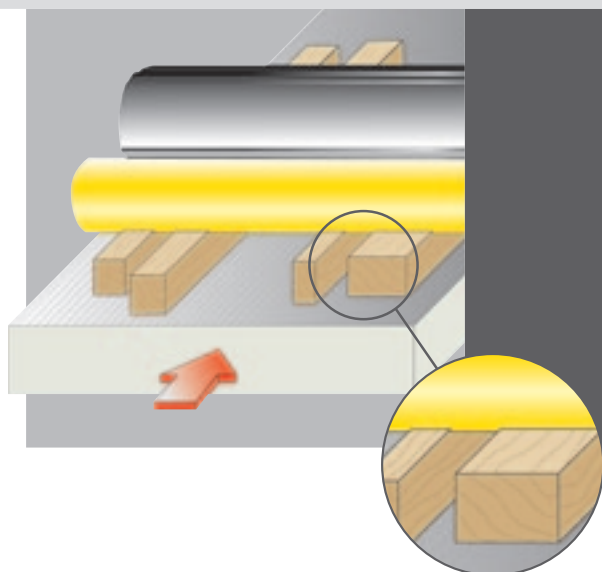

toptech

DUAL DENSITY ROLLER: THE OPTIMAL FEED ON WORK PIECES WITH DIFFERENT THICKNESSES.

The fluid feeding also provides the best quality in the simultaneous processing of multiple boards with different thicknesses. The **edges are not damaged** even when the work pieces are not perfectly aligned giving great results even with minimum removal. Suitable also for upgraded woods and/or thin thicknesses.

thickening **planers**

Devices and options.



toptech

PNEUMATIC ADJUSTMENT: THE PERFECT FEED IN ANY WORKING CONDITION.

The pressure exerted on the work piece can be changed at any time by adjusting the pneumatic load on the rollers for the **best finish and effectiveness of the feeding** of any material and in any working condition.



The unique ability to differentially set the pressure on the infeed and outfeed rollers allows the operator to combine maximum efficiency of the feed with the need for limited material removal. (*L'invincibile range*).

THICKENING TABLE WITH IDLE ROLLERS: IDEAL FOR HEAVY DUTY WOODWORKING OPERATIONS.

Particularly suitable for heavy duty woodworking operations and with rough work pieces. It enables the feeding of moist and/or resinous wood.



SCM MONOBLOCK CUTTERBLOCK: EASY AND RAPID IN USE.

Ease of use and rapid changeover of the throwaway knives due to the automatic locking/unlocking system and with self-adjustment. The cutter block is made from a single block of steel ensuring complete stability even under heavy dynamic loads.



**WORKTABLE EXTENSION:
DOUBLE PRODUCTIVITY.**

A single operator can easily move very long panels or introduce a second one without going to the outside to stop the first one.

THICKNESSING PLANERS	L'INVINCIBILE		CLASS		NOVA	
	S 6300	S 5200	S 630	S 520	S 630	S 520
2 speeds powered work table movement	S	S	S	S	S	S
2 axes "Ready" electronic control	S	S	-	-	-	-
Electronic digital readout for working height	-	-	S	S	-	-
Analogic readout of stock removal height	-	-	-	-	S	S
Feed speed with electronic adjustment by means of inverter from 4 to 20 m/min	S	S	S	S	-	-
No.4 feed speeds: 5-8-12-18 m/min	-	-	-	-	S	S
First front roller in helicoidal grooved steel	S	S	S	S	S	S
First front roller with rubber coating	O	O	O	O	-	-
First front roller with two different types of rubber	O	-	O	-	-	-
First sectional feed roller in steel	O	O	O	O	O	O
No. 2 outfeed rollers	S	S	S	S	O	O
Outfeed rubber-coated roller/s	S	S	S	S	S	S
Pneumatic pressure with independent adjusting on the front/outfeed rollers	S	S	-	-	-	-
Adjustable pneumatic pressure on the feed rollers	-	-	O	O	-	-
Work table with no. 2 idle rollers	O	O	O	O	O	O
"Tersa" monoblock cutterblock with throwaways knives	O	O	O	O	O	O
Worktable extension	O	O	O	O	-	-

S= standard O= option -= not available

combined surfacing-thicknessing planers

Easy and rapid to use with great performance in a limited space.



COMBINED SURFACING-THICKNESSING PLANERS		CLASS	NOVA
		FS 520	FS 410
Cutterblock diameter (no. of knives)	mm	120 (4)	95 (4)
Spindle speed	rpm	5.000	5.000
Main motor power	kW	5	7
Working width	mm	520	410
Exhaust outlet diameter	mm	120	120
Exhaust air consumption to 25 m/min	m ³ /h	1.050	1.010
Basic machine weight	kg	1.010	550
Surface Planer			
Work tables total length	mm	2.300	2.200
Infeed work table length	mm	1.180	1.080
Surface fence dimensions	mm	1.200x190	1.200x160
Surface fence tilting		from 90° to -45°	from 90° to -45°
Thicknessing Planer			
Work table dimensions	mm	520x900	410x775
Maximum working height	mm	250	240
Minimum working height	mm	3	3,5
Maximum removal in a single passage	mm	8	5
Feed speed	m/min	5-8-12-18	6-12



combined surfacing-thicknessing planers

Devices and options.



toptech

SERVO SYSTEM

**FOR THE OPENING OF THE TABLES:
SPEED, ERGONOMICS AND SAFETY.**

Changing the process from surfacing to thicknessing is now easy, safe and effortless due to the two buttons on the front of the machine that, as well as automatically raising the work tables, position the related extraction hood and the safety system

(standard feature on fs520 class, CE configuration).



<http://goo.gl/ke6bj>

**SIMULTANEOUS RAISING OF THE WORK TABLES:
A GUARANTEE OF PERFECT PLANARITY.**

The system allows the changeover from planer to thicknesser with a single movement ensuring working rapidity and precision.



COMBINED SURFACING-THICKNESSING PLANERS	CLASS	NOVA
	FS 520	FS 410
Servo-assisted system for working change (CE machine)	S	-
Powered movement of work table , 2 speeds	S	O
Electronic positioning for work table	O	-
Electronic digital readout for working height	S	O
Analogic readout of cutting depth for surface planer	S	S
No. 4 feed speed: 5-8-12-18 m/min with manual selection	S	-
No. 2 feed speed: 6-12 m/min with manual selection	-	S
First front roller in helicoidal grooved steel	S	S
First front sectioned roller in steel	O	-
Outfeed rubber-coated rollers	S	S
Work table with no. 2 idle rollers	O	-
“Tersa” monoblock cutterblock with throwaways knives	O	-
Mortiser	O	O
Additional overturning fence for processing of thin workpieces	O	O

S= standard O= option -= not available

planers

Overall dimensions.

SURFACE PLANERS

dimensions

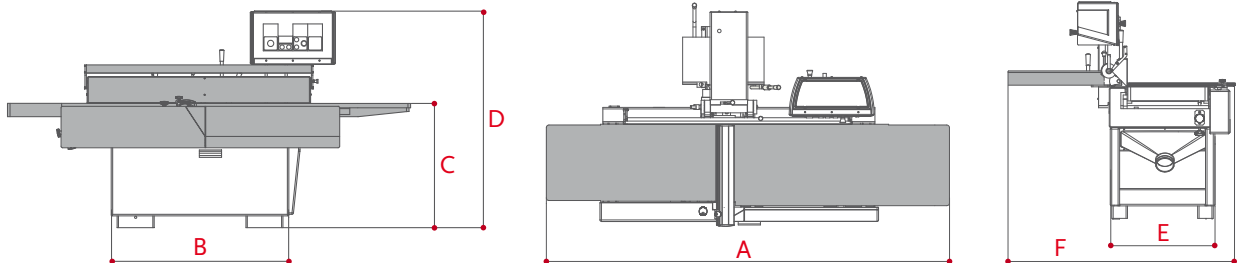

SURFACE PLANERS			L'INVINCIBILE		CLASS		NOVA	
			F 5200	F 520	F 410	F 520	F 410	
A	mm	3.008	2.730	2.610	2.730	2.610		
B	mm	1.200	1.200	1.200	1.140	1.140		
C	mm	844	844	844	844	844		
D	mm	1.466	1.385	1.385	-	-		
E	mm	648	688	558	648	538		
F	mm	1.416	1.416	1.155	1.415	1.150		

THICKENING PLANERS

dimensions

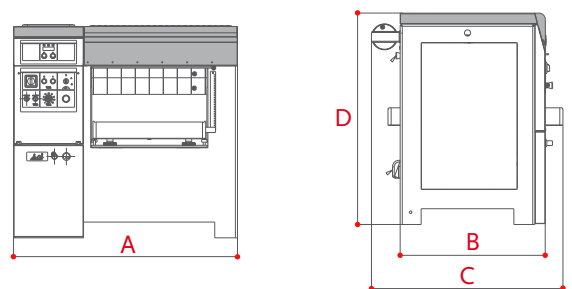

THICKENING PLANERS			L'INVINCIBILE		CLASS		NOVA	
			S 6300	S 5200	S 630	S 520	S 630	S 520
A	mm	1.280	1.130	1.280	1.130	1.275	1.140	
B	mm	770	740	770	740	725	705	
C	mm	1.095	1.017	1.095	1.017	1.080	1.003	
D	mm	1.219	1.214	1.219	1.214	1.204	1.204	



COMBINED SURFACING-THICKNESSING PLANERS

dimensions

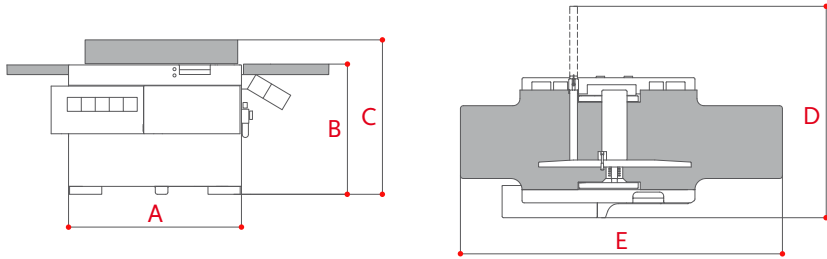

COMBINED SURFACING-THICKNESSING PLANERS		CLASS	NOVA
		F 520	F 410
A	mm	1.235	1.030
B	mm	930	905
C	mm	1.103	1.100
D	mm	1.510	1.200
E	mm	2.300	2.200

SINCERT



The technical data can vary according to the requested machine composition. In this catalogue, machines are shown with options. The company reserves the right to modify technical specifications without prior notice; the modifications do not influence the safety foreseen by the CE Norms.

 **scm**
 **minimax**
 **scm tecmatic**

 **scm**
 **routech**
 **celaschi**
 **dmc**
 **superfici**
 **sergiani**
 **gabbiani**
 **morbidelli**
 **mahros**
 **stefani**
 **cpc**
 **sag**

 **scmgroup**
 **delmac**
 **scmfonderie**
 **steelmec**
 **hiteco**
 **es**
 **csr**

 **CMS Cms**
wood technology

 **CMS Cms**
advanced materials technology

 **CMS Brembana**
stone technology

 **CMS Brembana**
glass technology

 **CMS CmsPlast**
plastic technology

 **CMS Tecnocut**
waterjet technology

 **CMS Balestrini**

1 large industrial group
18 production sites
30 specialist brands
21 foreign branches
more than 50 years in business
70% exports
350 agents and dealers
365 registered patents
500 support technicians
3.000 square metre showroom
10.000 classic and professional
machines made per year
240.000 square metres
of production space



passion**technology**performance
www.scmgroup.com

scm  **group**



the best global partner that is very close to woodworking companies.





SCM GROUP SPA SCM

sale offices: via Casale, 450 - 47826 Villa Verucchio, Rimini - Italy

tel. +39 0541 674111 - fax +39 0541 674274 - scm@scmgroup.com - www.scmgroup.com



00L0076165B